

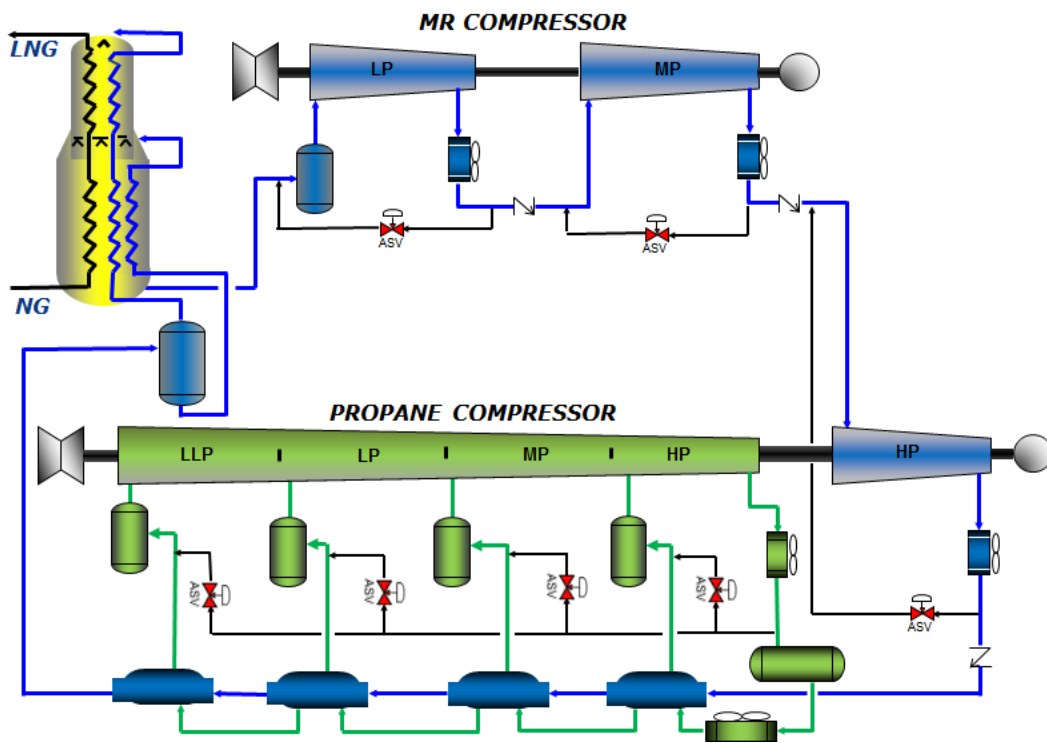

# Stop the Domino Effect



**Publish Date:** 3/1/2014  
**Author:** Wayne Jacobson

Effective control solution eliminates cascading trips at LNG plant.

When a million dollar piece of turbomachinery shuts down at an LNG plant as the result of a cascading trip, it causes a domino effect of problems that go well beyond machine or process malfunction. Not only does a hard shutdown of a machine under full load decrease the lifespan and components of the machine due to the stress associated with the shutdown, the extra length of time required to get an LNG train back online causes considerable delays in production and significant profit loss. Avoiding the scenario altogether is the ideal solution.

### Operational challenges

Compressor Controls Corporation (CCC) was recently tasked with helping an LNG plant with interdependent compressor strings create a control system modification in which the compressors could operate with more independence, avoiding unnecessary machine trips caused by surge and excessive recycle that could overload the compressor drivers. The client’s LNG plant design included a four-stage sidestream Propane compressor, and a three-stage Mixed Refrigerant (MR) compressor, with the final-stage of the MR train — the HP stage — located on the same driver shaft as the propane compressor. Both compressor strings operate at near constant speed with an underspeed trip setting very close to normal operating speeds. This split-shaft design was created to better balance power between the two compressor strings. However, both strings rely on the HP stage in order to operate properly — one by shared driver shaft arrangement and the other by shared flow of the closed refrigeration process loop. The interdependence created by this design meant that if one compressor would trip it would cause a cascading trip, shutting the other compressor down unnecessarily, thereby, causing additional losses in LNG production.

For example, when the propane circuit would trip, the HP stage of the MR machine would also trip due to its location on the same shaft. The tripping of the MR HP stage resulted in a sudden loss of flow through the MR LP and MP stages, causing both compressor stages to go into surge and eventually trip on excessive surge.

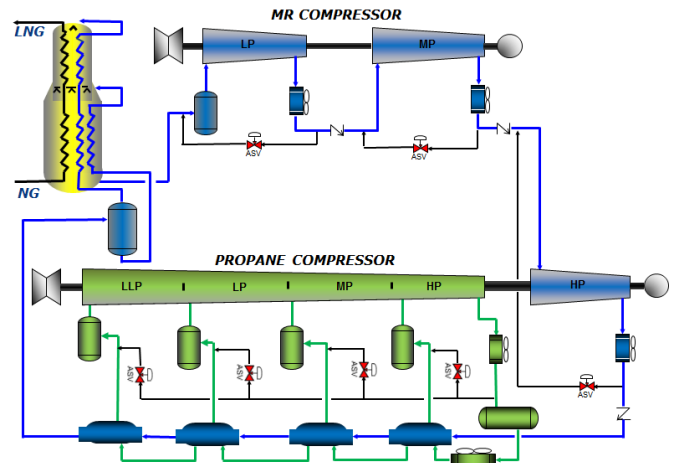

Conversely, when the MR circuit would trip, the HP stage had a sudden loss of flow and would surge due to the MR LP and MP anti-surge and bypass valves tripping open and the MP stage discharge check valve closing. In addition, the drop in MR flow through the propane chillers caused a loss of propane vapor production, requiring the propane compressor to counteract by quickly opening its anti-surge valves. The propane string would reach the gas turbine power limit and shutdown on underspeed.

### Solution

The cascade trips can result from a variety of events including planned shutdowns, emergency shutdowns, helper motor/turbine trips as well as process trips. Each type of event needs to be considered when determining a preventive solution. Other contributing factors to cascading trips include excessive piping volumes, undersized or oversized anti-surge valves and slow responding anti-surge valves — all of which require consideration, as well.

Analysis of the events and other information led to the understanding that the existing design concept based on the operation of a closed loop control system may be inadequate to prevent the described domino effect, and that the control system operation would have to be supplemented by an additional open loop, feed forward response. This response would, in essence, put the system in a defensive posture once an extreme disturbance was detected, and once the disturbance has passed, would return the operation to the closed loop control system.

To provide a solution which would avoid interdependent tripping without over-aggressive tuning, CCC developed a modification to the control system in which one machine could shut down without impacting the other. This was achieved by allowing the anti-surge valves of one string to temporarily open when the other unit shutdown. For example, if the propane compressor — and subsequently the MR HP stage — shutdown, the anti-surge valves on the string fully open in an effort to protect machine. The new CCC control command also temporarily opens the anti-surge valves on the LP and MP stages of the MR machine and holds for the disturbance to pass. The MR would continue to run under full recycle and shutdown on surge would be prevented.

Modification enhancements to address this challenge included separate unload commands as well as three new parameters for each anti-surge controller:

- A ramp rate configurable up to 100 percent per second
- An unload clamp to position the valve at the desired opening
- A hold timer to keep the valve at the fixed position for a configurable period

Each parameter is independent of one another and adjustments can easily be made by Operations on site.

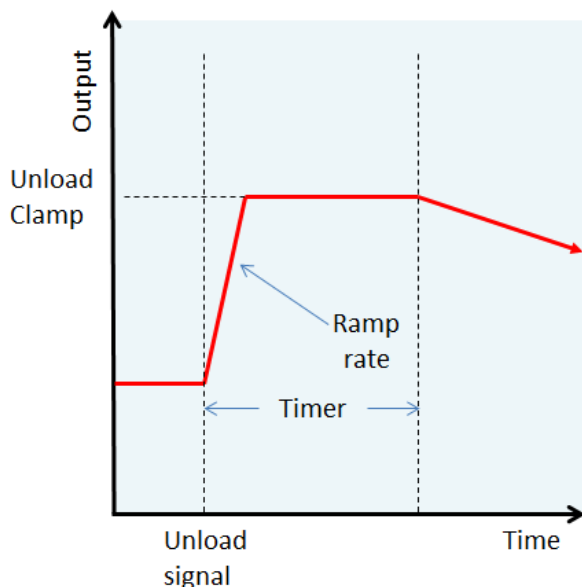

Ramp rates for all three MR stages were set to in affect step open the anti-surge valves with target opening positions 10 to 20 percent above their full recycle positions. Since the effect on the Propane circuit was less severe, the ramp rates for opening the anti-surge valves were more moderate and the opening positions were set close to their corresponding full recycle positions.

### Using Simulation

Simulation was used to verify the functionality as well as to come up with preliminary settings for the new unload parameters. To enhance the accuracy of the simulation, an emulator of the antisurge control system was interfaced with the simulation. Since the emulator mimics the exact functionality and settings of the client’s antisurge control system, testing on the actual system was kept at a minimum and only minor adjustments were made to settings.

### Conclusion

The desired end result was to avoid surging of compressor stages which can result in a shutdown of the compressor string due to excessive surging or speed reduction caused by driver power limitations. This was achieved by opening the anti-surge valves fast and far enough to provide sufficient flow through the compressor, preventing surge, but not so far as to reach the gas turbine power limit reached during identified trip events.

With the modifications initiated by CCC and the client, the interdependent compressor strings are now automatically sequenced to maintain consistent and safe operation of the online string when the other string trips. Similar modifications have been implemented at other LNG sites utilizing the split shaft compressor designs as well as sites having traditional common shaft designs but still have the interdependency due to the process design. The results have been a reduction in compressor surge and unnecessary shutdown of rotating equipment as well as quicker restarts of the process leading to fewer losses in production.

## About The Author:



Wayne Jacobson is global technology manager for Compressor Controls in Des Moines, Iowa. He joined the company in 1996 as a systems engineer. He has a degree in mechanical engineering. His responsibilities include

providing technical guidance and support, developing control applications, maintaining standard engineering and overseeing the overall technical development of the company's engineering staff.